

Veto Burner Head

160, 240, 360, 480, 640, 800 and 990 kW



User Manual Installation and Service

Retailer:

Keep this manual.

Contents

1. Introduction	4
1.1. Contact information.....	4
1.2. Type plate information	5
1.3. Warranty	6
1.3.1. Deficiencies in delivery and return of warranty parts	7
1.3.2. Processing of warranty matters.....	7
1.4. Product markings.....	8
1.5. Product documentation	11
1.6. Version history	11
1.7. Document conventions	12
1.7.1. Symbols.....	12
1.7.1. Other document conventions	12
2. General safety and warnings.....	14
3. Product description	16
3.1. Burner heads 160-640 kW (A•T Log and Lambda 5S)	16
3.2. Burner heads 160-640 kW (Veto XL)	18
3.3. Burner heads 800 and 990 kW	19
3.4. Moving grate	20
3.5. Product variants.....	20
4. Technical data	22
5. Installation.....	26
5.1. Checking the device.....	26
5.2. Installing the burner head to the boiler	26
5.3. Installing the moving grate with A•T Log and Lambda 5S control units	28
5.3.1. Installing burner heads 160-640 kW with Veto XL control unit.....	30
5.3.2. Installing burner heads 800-990 kW with Veto XL control unit.....	31
5.4. Before taking the system into use	32
6. Service.....	34
6.1. Service schedule	35
6.2. Preparing for service.....	35
6.3. Removing ash from inside the burner.....	36
6.4. Cleaning the burner head air holes	37
6.5. Changing bottom bricks	38

7. Troubleshooting	40
7.1. Burner heads with a moving grate.....	40
7.1.1. Grate actuator bearing damaged	40
7.1.2. Ash does not exit the burner head	40
7.2. Burner heads with a moving or stationary grate	40
7.2.1. Ash does not exit the burner head	40
7.2.2. Unburnt fuel in the ash chamber	41
7.2.3. Bottom bricks burnt off	41
7.2.4. Burner smokes.....	42
7.3. Linear actuator.....	42
7.3.1. Moving grate does not move.....	42
8. Device components and spare parts.....	44
9. Disposal of the burner head	54

1. Introduction

You have made a good choice in purchasing a Veto burner head. The burner head together with a stoker device and a Veto boiler offers a pure, economic, efficient, and near-emission-free way of burning renewable energy sources approved by the manufacturer. By avoiding using fossil fuels, you can considerably diminish the burden on the environment and prevent global warming.

This manual is for using the Veto burner head. To gain the best possible benefit of the device, read this instruction manual carefully before installing, connecting or using the device. If all the instructions are followed, the device provides a long-lasting, economic, and faultless performance. Only use this manual with the device it was delivered with.

The instructions, descriptions and technical information are based on the latest knowledge on the structure of the burner head at the moment this instruction manual is created. We constantly develop our products further, and we therefore reserve the right to make any alterations without prior notice.



Improper use of the product can result in serious injury. To avoid injury, read and carefully follow all instructions provided in this manual before installing, operating, or servicing the device.



The instructions provided in this manual are recommendations. Laws and regulations of local authorities override our recommendations.

1.1. Contact information

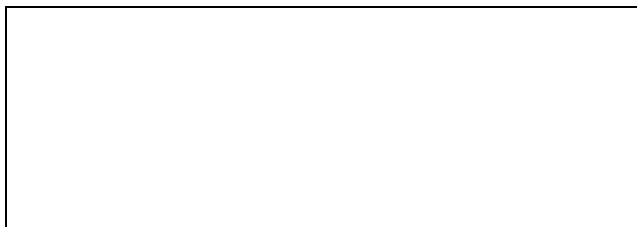

1.2. Type plate information

Write down the information from the type plate for easy reference. You need the information when, for example, ordering spare parts or claiming warranty.

Figure 1 Type plate location

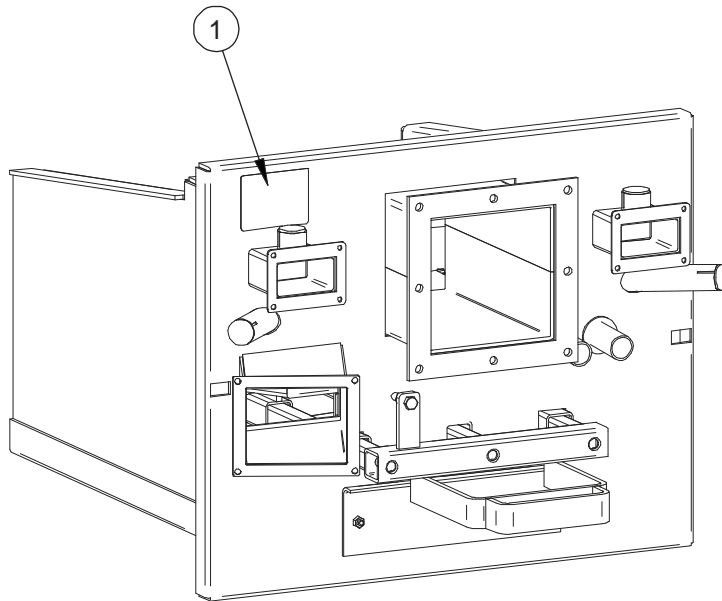

1 Location of the type plate

Table 1 Type plate information

Model	
Manufacturing year	
Serial number	

1.3. Warranty

The manufacturer Veljekset Ala-Talkkari Oy grants a warranty for the products that it manufactures and markets. The user is liable for damage resulting from use of the equipment for any purpose other than that for which it was designed.

The warranty period is one year from the date of delivery (EU countries: The device has a warranty that complies with the legislation in the country of use).

The warranty for parts changed under the warranty continues until the end of the original warranty period.

The prerequisite for warranty is observation of the installation, use, service and safety instructions for the device.

Continuation of the warranty for the device requires the use of original spare parts or those approved by the manufacturer. Service and any repairs performed during the warranty period must be assigned to a service company approved by the manufacturer.

Compensation for service during warranty period can also be claimed if:

- The service visit is unnecessary (the reason is not covered by the warranty).
- The manufacturer's instructions concerning installation, use and care have not been observed.
- Corrective measures were not taken immediately upon observation of the fault.

The warranty covers:

- Manufacturing and raw material defects in products manufactured by Veljekset Ala-Talkkari Oy.

The warranty does not cover:

- Defects or damage caused by:
 - Natural wear (spring agitator springs, feeding screw, grates, blades, feet, etc.)
 - Misuse of the product or use in violation of the instructions
 - Neglect of service in accordance with the instruction manual
 - Change work or repairs made without the manufacturer's consent
 - Other manufacturers' control devices or programs
 - Safety equipment that deviates from that delivered or is installed contrary to the instructions
 - External factors
- Breakage of parts preventing overloading
- Indirect costs or down time, or the resulting financial losses
- Work or travel costs unless separately agreed in advance with the manufacturer

1.3.1. Deficiencies in delivery and return of warranty parts

- Deficiencies in delivery must be reported within seven (7) days of the delivery.
- Broken warranty parts must be returned to the plant for a warranty inspection (include a warranty report).
- A part to replace the broken part can be delivered prior to warranty processing.
- An invoice for returned warranty parts that do not meet the terms of the warranty can be sent after warranty processing.
- The client can be charged for parts that are not returned upon request.

1.3.2. Processing of warranty matters

- The retailer is the primary contact channel in warranty matters and problem situations.
- The retailer handles processing of the matters with the manufacturer.
- The retailer must be provided with the following information: brand, model and purchasing date for the device and the serial number of the device from the type plate.
- Warranty compensation is subject to determination of the cause of the damage and agreement with the manufacturer concerning the repair prior to initiating any repair work.

1.4. Product markings

NOTICE

Pay attention to the warning and information stickers: they help you to avoid risks.

Figure 2 Product marking locations

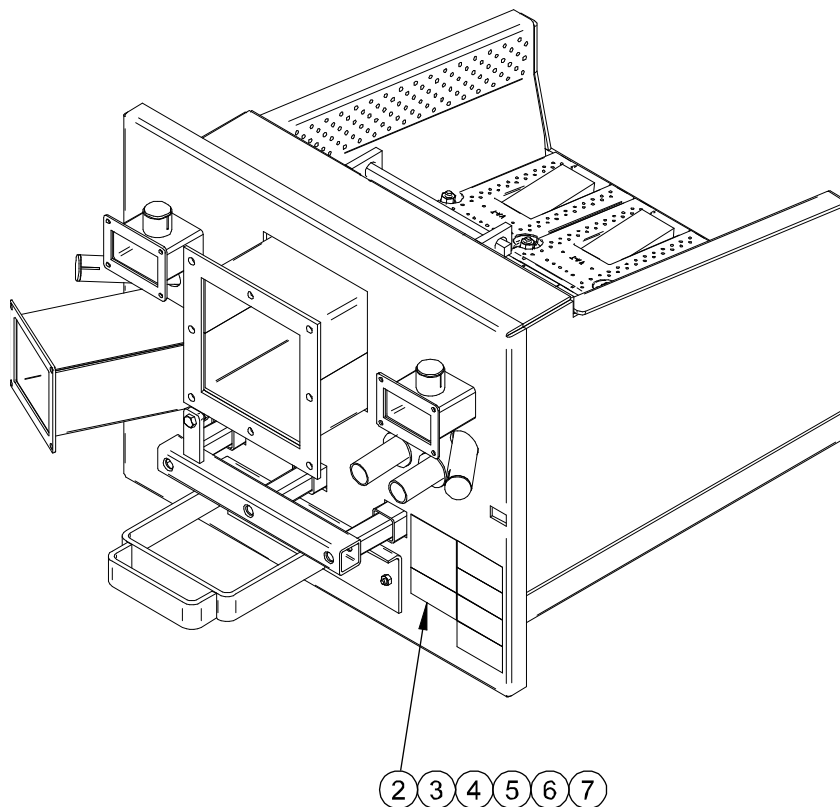















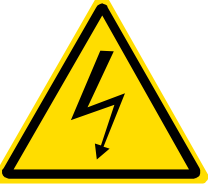
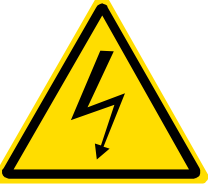
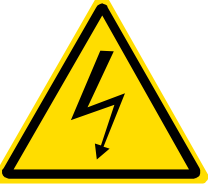



Table 2 Product markings on the device

Item	Product marking								
2	<table border="1" style="width: 100%; border-collapse: collapse;"> <tr> <td colspan="2" style="background-color: #ff0000; color: white; text-align: center; padding: 5px;">⚠ DANGER</td> </tr> <tr> <td style="width: 30%; text-align: center; vertical-align: top; padding: 5px;">  </td> <td style="padding: 5px;"> <p>Risk of carbon monoxide poisoning and fire</p> </td> </tr> <tr> <td style="text-align: center; vertical-align: top; padding: 5px;">  </td> <td style="padding: 5px;"> <p>Leaving covers or hatches open leads to immediate risk of fire when device is in operation.</p> <p>Close covers and hatches airtight. Ventilate properly before entering fuel bin.</p> </td> </tr> <tr> <td style="text-align: center; vertical-align: top; padding: 5px;">  </td> <td style="padding: 5px;"> <p>Always work in pairs. When entering fuel bin have a person outside fuel bin to secure your safety.</p> </td> </tr> </table>	⚠ DANGER			<p>Risk of carbon monoxide poisoning and fire</p>		<p>Leaving covers or hatches open leads to immediate risk of fire when device is in operation.</p> <p>Close covers and hatches airtight. Ventilate properly before entering fuel bin.</p>		<p>Always work in pairs. When entering fuel bin have a person outside fuel bin to secure your safety.</p>
⚠ DANGER									
	<p>Risk of carbon monoxide poisoning and fire</p>								
	<p>Leaving covers or hatches open leads to immediate risk of fire when device is in operation.</p> <p>Close covers and hatches airtight. Ventilate properly before entering fuel bin.</p>								
	<p>Always work in pairs. When entering fuel bin have a person outside fuel bin to secure your safety.</p>								
3	<table border="1" style="width: 100%; border-collapse: collapse;"> <tr> <td colspan="2" style="background-color: #ffa500; text-align: center; padding: 5px;">⚠ WARNING</td> </tr> <tr> <td style="width: 30%; text-align: center; vertical-align: top; padding: 5px;">  </td> <td style="padding: 5px;"> <p>Moving parts can crush and cut. Blower impeller rotates. Keep fingers away from rotating impeller. Switch off control unit before servicing.</p> </td> </tr> </table>	⚠ WARNING			<p>Moving parts can crush and cut. Blower impeller rotates. Keep fingers away from rotating impeller. Switch off control unit before servicing.</p>				
⚠ WARNING									
	<p>Moving parts can crush and cut. Blower impeller rotates. Keep fingers away from rotating impeller. Switch off control unit before servicing.</p>								
4	<table border="1" style="width: 100%; border-collapse: collapse;"> <tr> <td colspan="2" style="background-color: #ffa500; text-align: center; padding: 5px;">⚠ WARNING</td> </tr> <tr> <td style="width: 30%; text-align: center; vertical-align: top; padding: 5px;">  </td> <td style="padding: 5px;"> <p>Moving parts can crush and cut. Burner runs intermittently and starts without warning. Even when device is switched off springs may have potential energy. Do not enter fuel bin while power is on.</p> </td> </tr> </table>	⚠ WARNING			<p>Moving parts can crush and cut. Burner runs intermittently and starts without warning. Even when device is switched off springs may have potential energy. Do not enter fuel bin while power is on.</p>				
⚠ WARNING									
	<p>Moving parts can crush and cut. Burner runs intermittently and starts without warning. Even when device is switched off springs may have potential energy. Do not enter fuel bin while power is on.</p>								
5	<table border="1" style="width: 100%; border-collapse: collapse;"> <tr> <td colspan="2" style="background-color: #ff0000; color: white; text-align: center; padding: 5px;">⚠ DANGER</td> </tr> <tr> <td style="width: 30%; text-align: center; vertical-align: top; padding: 5px;">  </td> <td style="padding: 5px;"> <p>Hazardous voltage will cause severe injury or death. Turn off power. Wait 15 min before service. Although control unit is dead, supply voltage from frequency converter remains.</p> </td> </tr> </table>	⚠ DANGER			<p>Hazardous voltage will cause severe injury or death. Turn off power. Wait 15 min before service. Although control unit is dead, supply voltage from frequency converter remains.</p>				
⚠ DANGER									
	<p>Hazardous voltage will cause severe injury or death. Turn off power. Wait 15 min before service. Although control unit is dead, supply voltage from frequency converter remains.</p>								

Item	Product marking
6	<div style="border: 1px solid black; padding: 5px;"> <div style="background-color: #FFC000; text-align: center; padding: 2px;">⚠ WARNING</div> <div style="display: flex; align-items: center;"> <div style="flex: 1; text-align: center;">  </div> <div style="flex: 2; padding-left: 10px;"> <p>Read manual before using device.</p> <p>Failure to follow instructions could result in death, serious injury or damaged device.</p> </div> </div> </div>
7	<div style="border: 1px solid black; padding: 5px;"> <div style="background-color: #FFC000; text-align: center; padding: 2px;">⚠ WARNING</div> <div style="display: flex; align-items: center;"> <div style="flex: 1; text-align: center;">  </div> <div style="flex: 2; padding-left: 10px;"> <p>Risk of burn and fire</p> <p>Device is hot and remains hot after switch-off.</p> <p>Do not cover burner head. Keep it clean. Be cautious in boiler room.</p> </div> </div> </div>

1.5. Product documentation

Table 3 Related product documentation

Manual name	Identification
Boilers	
Veto Stoker Boiler 30, 60, 75, 80, 100, 120, 150, 220kW	VSB20130328EU1.0
Veto Stoker Boiler 300, 400, 500, 700, 990kW	TH300-700kW_11.11.2009
Control unit	
A•T Log-1 and A•T Log-2 Control Unit User Manual	ATL20130328EU1.0
Lambda 5S control unit	039 028 06_LAMBDA 5S GB_v8
Burners	
Veto 6 User Manual	V6T20130328EU1.0
Veto 8 User Manual	V8T20130328EU1.0
Veto Spring Agitator User Manual	VST20130328EU1.0
Other	
TA control Unit Data Sheet	TAC20130328EU1.0
Veto Burner Head 160, 240, 360, 480, 640, 800, 990 kW User Manual	VBR20130328EU1.0
Boiler Transport and Storage	SBT20121221US1.0
Veto Burner Head 160, 240, 360, 480, 640, 800, 990 kW Transport and Storage	VBT20121221US1.0
Veto 6 Transport and Storage	V6T20130328US2.0
Veto 8 Transport and Storage	V8T20130328US2.0
Veto Spring Agitator Transport and Storage	VST20121221US1.0

1.6. Version history





Table 4 Document version history

Version	Date	Changes
EN1.0	28.03.2013	First version

1.7. Document conventions

1.7.1. Symbols

Table 5 Symbols used in this document

Symbol	Explanation
	Indicates a hazardous situation which, if not avoided, will result in death or serious injury.
	Indicates a hazardous situation which, if not avoided, could result in death or serious injury.
	Indicates a hazardous situation which, if not avoided, could result in minor or moderate injury.
	Indicates special information to the reader, but not related to personal injury.

1.7.1. Other document conventions

Table 6 Document conventions

Item	Convention	Example
Italics	Indicates a reference within this document.	Refer to <i>1.7.1. Document conventions</i> .

2. General safety and warnings

These general safety instructions help you to avoid dangerous situations when installing, operating or servicing the device. Important safety instructions are also presented in the beginning of each section.

DANGER

Do not make any alterations to the original device design. Any alterations to the product may result in serious hazard to people, property or environment.

Installation and service of the device must only be performed by an authorized professional installer following all the requirements of the authority having jurisdiction over the installation.

Incorrect installation, operation, and service of this device could result in severe personal injury, death, or substantial property damage from fire, carbon monoxide poisoning, soot or explosion.

Risk of fire! Fuel remains on the floor may catch fire from a spark, and fire may spread to the structure of the building. Keep the boiler room tidy.

Risk of fire! Do not use the boiler room as a general storage space due to fire hazard.

Risk of carbon monoxide poisoning! When using the device, always ensure that the service doors are completely shut to prevent hot combustion gas from entering the boiler room.

WARNING

The boiler must only be used together with a Veto burner device and a control unit.

Risk of burn! The service doors are always hotter than the rest of the boiler surface. Also some of the pipes are hot. Always be cautious in the boiler room.

Risk of carbon monoxide poisoning and fire! Keep ash in a metal container.

CAUTION

Ashes or fuel may contain constituents causing allergic reactions.

- Use appropriate protective equipment such as respiration protector when handling ashes or fuel.
- Use clothes and gloves made of infusible materials when servicing the boiler.

3. Product description

A complete burner head delivery always includes:

- Burner head
- Blowers
- Blower gaskets
- Driving mechanism
- Cleaning rake
- Bolts, nuts and washers needed for installation
- User manual

NOTICE

A spare part delivery includes only the burner head.

3.1. Burner heads 160-640 kW (A•T Log and Lambda 5S)

A burner head delivery includes:

- Burner head
- Blowers
- Blower gaskets
- Cleaning rake
- Gearbox
- Electric motor
- Gearbox mounting base
- Control shaft
- Screw for adjustment plate
- Fixing plate
- Limit switch
- Bearings
- Bolts, nuts and washers needed for installation
- User manual

Figure 3 Burner head 160-640 kW

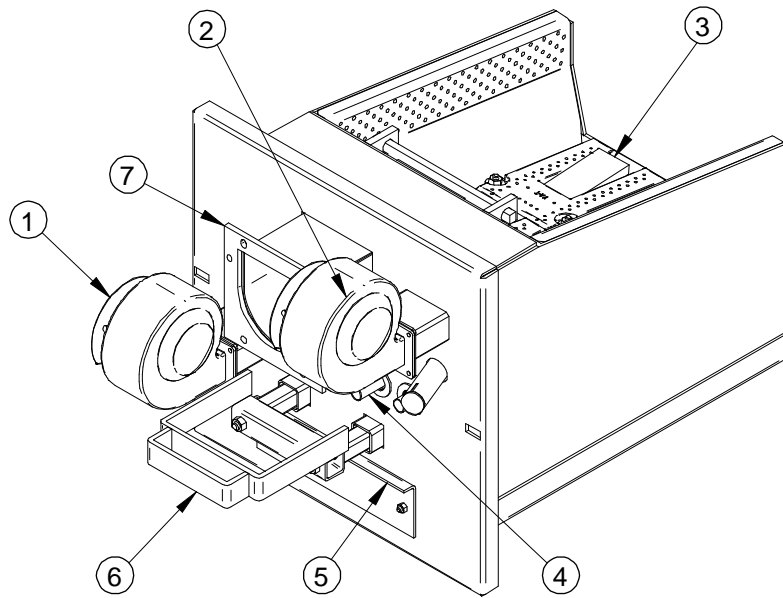

- 1 Primary air blower
- 2 Secondary air blower(s)
- 3 Grate tongue
- 4 3/4" 160-240kW/1" 360-640 kW connection to the cooling system of the burner head
- 5 Ash removal hatch
- 6 Grate push bars
- 7 Feeding chute

3.2. Burner heads 160-640 kW (Veto XL)

A burner head delivery includes:

- Burner head
- Blowers
- Blower gaskets
- Cleaning rake
- Air distribution box
- Linear actuator
- Bolts, nuts and washers needed for installation
- User manual

Figure 4 Burner head 160-640 kW (Veto XL)

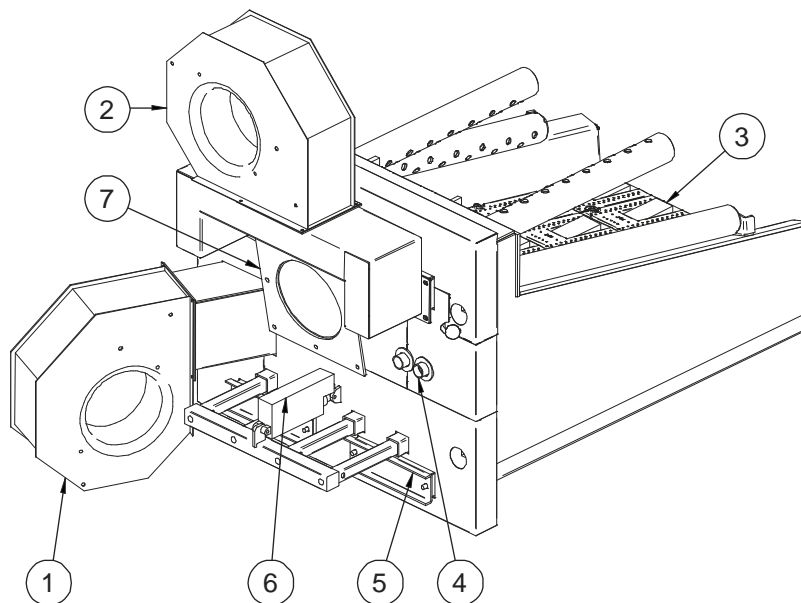

- 1 Primary air blower
- 2 Secondary air blower
- 3 Grate tongue
- 4 3/4" 160-240kW/1" 360-640kW connection to the cooling system of the burner head
- 5 Ash removal hatch
- 6 Linear actuator
- 7 Feeding chute

3.3. Burner heads 800 and 990 kW

A burner head delivery includes:

- Burner head
- Blowers
- Blower gaskets
- Cleaning rake
- Air distribution box
- Hoses
- Blower support
- Bolts, nuts and washers needed for installation
- User manual

Figure 5 Burner head 800 and 990 kW

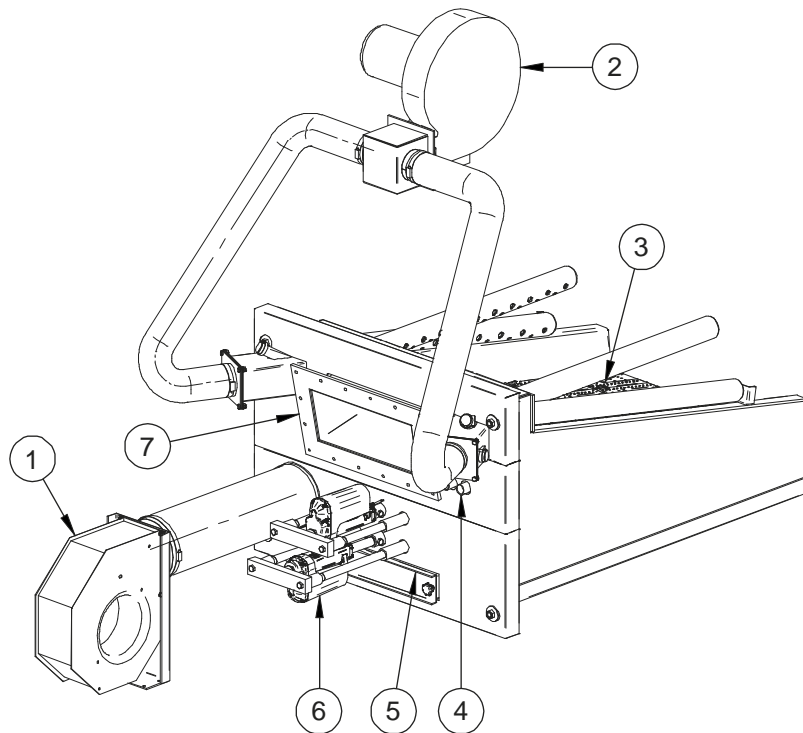

- 1 Primary air blower
- 2 Secondary air blower
- 3 Grate tongue
- 4 1" connection to the cooling system of the burner head
- 5 Ash removal hatch
- 6 Linear actuators
- 7 Feeding chute

3.4. Moving grate

The operation of the moving grate is based on the movement of the grate tongues. A grate tongue makes a reciprocating motion returning inside a bottom brick. All the grate tongues move simultaneously except in burner heads 800 and 990 kW the lower and the upper part move at different intervals. The amount of grate tongues varies according to the output of the burner head. The function of the moving grate is controlled by adjusting the pause time between work times.

The purpose of the moving grate is to remove the ash from the grate system. The movement of the grate tongues keeps the holes in the grate system open. The moving grate also evens the incoming fuel into a broad layer.

To keep the burner efficiency high, the time settings of the moving grate should be readjusted always when the fuel type or the fuel moisture percent are changed. Also, when the fuel feed is changed, the time settings of the moving grate should readjusted. When readjusting the moving grate, observe the flame and the amount of unburnt fuel in the ash chamber. The fuel should be spread evenly and unburnt fuel should not get into the ash chamber.

NOTICE

Calculate the pause time of the moving grate cumulatively from the feeding screw pulse.

For example, the feeding screw pulse is 2 s and the moving grate pause time is 3 min. In this case, the feeding screw should do 90 operation times so that the moving grate should do one operation time.

The correct pause time for chips and pellet is 3-8 min. If the ash is hardened, the pause time should be 1-3 min. The correct pause time should be adjusted case by case.

3.5. Product variants

Table 7 Available feeding screw diameters for burner heads

Burner head (kW)	Feeding screw (mm)
160	Ø125 or Ø160
240	Ø125 or Ø160
360	Ø160
480	Ø200
640	Ø200
800	2xØ160
990	2xØ160

4. Technical data

Table 8 Requirements for burner heads with A•T Log-1 and A•T Log-2 control units or Lambda 5S control unit

Requirement	Burner head 160 kW	Burner head 240 kW	Burner head 360 kW	Burner head 480 kW	Burner head 640 kW
Rated output, kW	160	240	360	480	640
Size of the compensation air hole of the boiler room	1.5 x chimney diameter				
Weight, kg	150	180	300	370	480
Feeding screw diameter, mm	125	125	160	200	200
	160	160	-	-	-
Primary air blower	RFE140	RFE200	RFE200	RFE250	RFE250
Secondary air blower with Ø125 mm feeding screw	RFE140	RFE140	-	-	-
Secondary air blower with Ø160 mm feeding screw	2xRFE140	2xRFE140	2xRFE140	-	-
Secondary air blower with Ø200 mm feeding screw	-	-	-	2xRFE140	2xRFE140
Moving grate gearbox	RMI 50				
Moving grate rated output, kW	0.37				
Water cooling system	Yes				
Control unit	AT Log 1&2	AT Log 1&2	Lambda 5S	Lambda 5S	Lambda 5S
	Lambda 5 S	Lambda 5 S	-	-	-
Boiler	Veto 150	Veto 220	Veto 300	Veto 400	Veto 500
Bottom bricks	4	6	9	12	16

Table 9 Requirements for burner heads with Veto XL control unit

Requirement	Burner head 160 kW	Burner head 240 kW	Burner head 360 kW	Burner head 480 kW	Burner head 640 kW	Burner head 800 kW	Burner head 990 kW
Rated output, kW	160	240	360	480	640	800	990
Size of the compensation air hole of the boiler room	1.5 x chimney diameter						
Weight, kg	150	180	300	370	480	590	670
Feeding screw diameter mm	125	125	160	200	200	2 x 160	2 x 160
	160	160	-	-	-	-	-
Primary air blower	RFT200S	RFT200S	RFT200S	RFT250	RFT250	RFT280	RFT280
Secondary air blower with Ø125 mm feeding screw	RFT200S	RFT200S	-	-	-	-	-
Secondary air blower with Ø160 mm feeding screw	RFT200S	RFT200S	RFT200S	-	-	-	-
Secondary air blower with Ø200 mm feeding screw	-	-	-	RFT250	RFT250	-	-
Secondary air blower with 2 x Ø160 mm feeding screws	-	-	-	-	-	CMA531	CMA531
Moving grate linear actuator	Elero Junior	Elero Junior	Elero Junior	Elero Junior	Elero Junior	2 x Actuator LA36	2 x Actuator LA36
Water cooling system	Yes						
Control unit	XL						
Boiler	Veto 150	Veto 220	Veto 300	Veto 400	Veto 500	Veto 700	Veto 990
Bottom bricks	4	6	9	12	16	20	24

Table 10 Feed settings for Veto 8, Chipmatic, spring agitator, and spring agitator with silo

						Operating condition		Pause condition	
Fuel	Burner power kW	Heat value kW/kg	Moisture %	Blower setting	After-blow (s)	Pulse (ms)	Pause (s)	Pulse (ms)	Pause (min)
Wood chips	160	2.9	20	5	20	750	4	1500	10
Wood pellets	160	4.8	8-10	4	40	400	10	1500	10
Briquets	160	3.5	35	4	40	500	6	1500	10
Wood chips	240	2.9	20	5	20	1100	4	1500	10
Wood pellets	240	4.8	8-10	4	40	400	8	1500	10
Briquets	240	3.5	35	4	40	700	6	1500	10
Wood chips	360	2.9	20	6	20	2000	4	1500	10
Wood pellets	360	4.8	8-10	5	40	500	6	1500	10
Briquets	360	3.5	35	5	40	1000	5	1500	10
Wood chips	480	2.9	20	6	20	1150	4	1500	10
Wood pellets	480	4.8	8-10	5	40	500	9	1500	10
Briquets	480	3.5	35	5	40	700	5	1500	10
Wood chips	640	2.9	20	7	20	1750	4	1500	10
Wood pellets	640	4.8	8-10	6	40	600	8	1500	10
Briquets	640	3.5	35	6	40	1000	5	1500	10
Wood chips	800	2.9	20	-	20	3500	6	1500	10
Wood pellets	800	4.8	8-10	-	40	500	6	1500	10
Briquets	800	3.5	35	-	40	2	10	1500	10
Wood chips	990	2.9	20	-	20	5000	6	1500	10
Wood pellets	990	4.8	8-10	-	40	650	6	1500	10
Briquets	990	3.5	35	-	40	2500	10	1500	10

Table 11 Feed settings for Veto 6

						Operating condition		Pause condition	
Fuel	Burner power kW	Heat value kW/kg	Moisture %	Blower setting	After-blow (s)	Pulse (ms)	Pause (s)	Pulse (ms)	Pause (min)
Wood chips	160	2.9	20	5	20	3000	4	1500	10
Wood pellets	160	4.8	8-10	4	40	750	7	1500	10
Briquets	160	3.5	35	4	40	1000	5	1500	10
Wood chips	240	2.9	20	5	20	2000	1	1500	10
Wood pellets	240	4.8	8-10	4	40	800	5	1500	10
Briquets	240	3.5	35	4	40	1000	3	1500	10

5. Installation

DANGER

Installation of the device must only be performed by an authorized professional installer following all the requirements of the authority having jurisdiction over the installation.

WARNING

During installation, always follow official regulations, statutes, and installation instructions.

NOTICE

The connection between the burner head and the boiler must be tight.

5.1. Checking the device

- Check that the burner head delivery includes all the parts that it is supposed to. See 3 *Product description*.
- Check that the burner head is in good condition when delivered.

If a listed part is missing or there are damages in the delivery, contact your retailer.

5.2. Installing the burner head to the boiler

In the boiler, two or four screws are welded onto the edges of the burner head opening. The holes in the burner head flange match with the screws.

1. Seal off the burner head flange with ceramic wool and push the burner head horizontally into the boiler. Use a trolley jack.
2. Install needed blowers and feeding chutes.
Install all the feeding chutes in a straight line seen from side and from above, and also at right angle to the burner head. Use for example a straight blank wood before the final tightening of the screws. An incorrect installation may lead to excessive wear of the equipment, which will not be covered by the warranty, and also air leaks.

A circulation water pump must be installed to the system. A shut-off valve (opened with a wrench) must be installed to the output and to the return sides of the system for service purposes.

Figure 6 Connecting the burner head to the boiler, piping

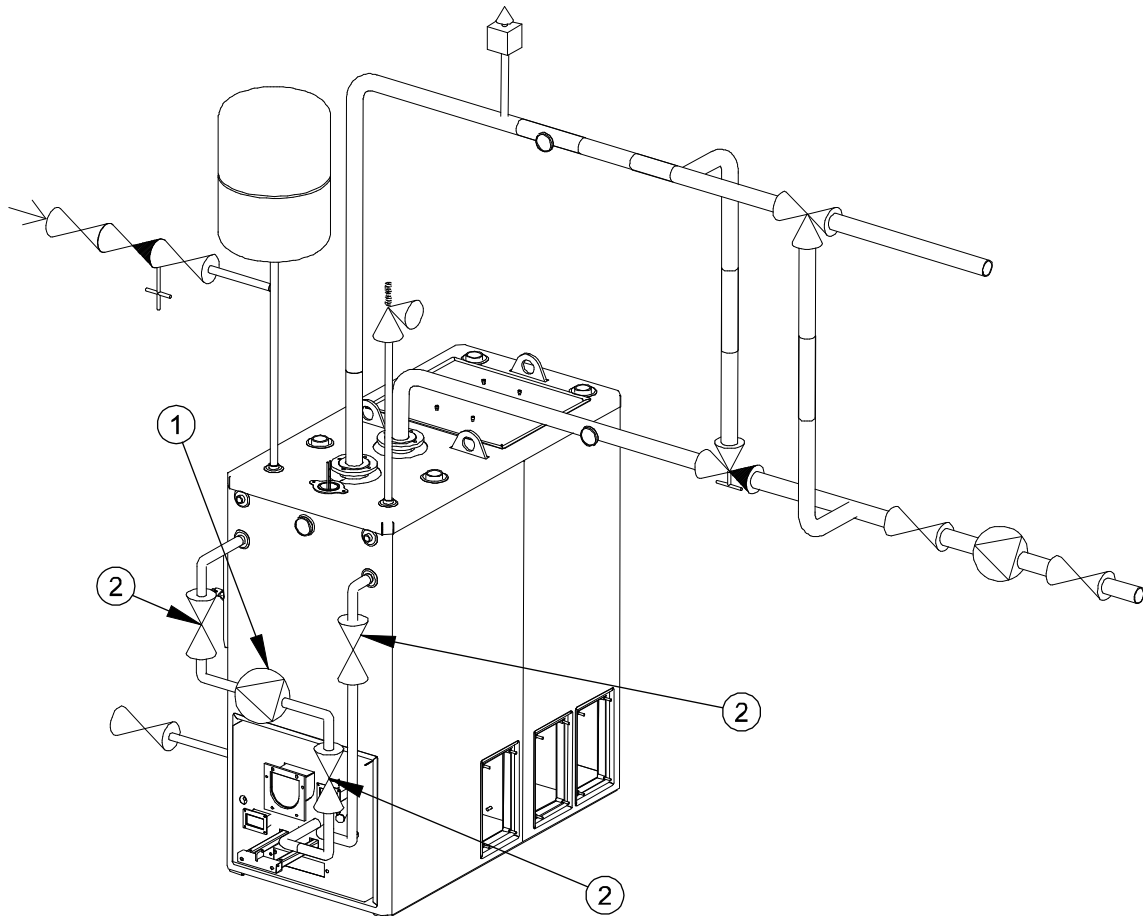

- 1 Circulation water pump
- 2 Shut-off valve (shut off with a tool)

5.3. Installing the moving grate with A•T Log and Lambda 5S control units

Figure 7 Moving grate equipment

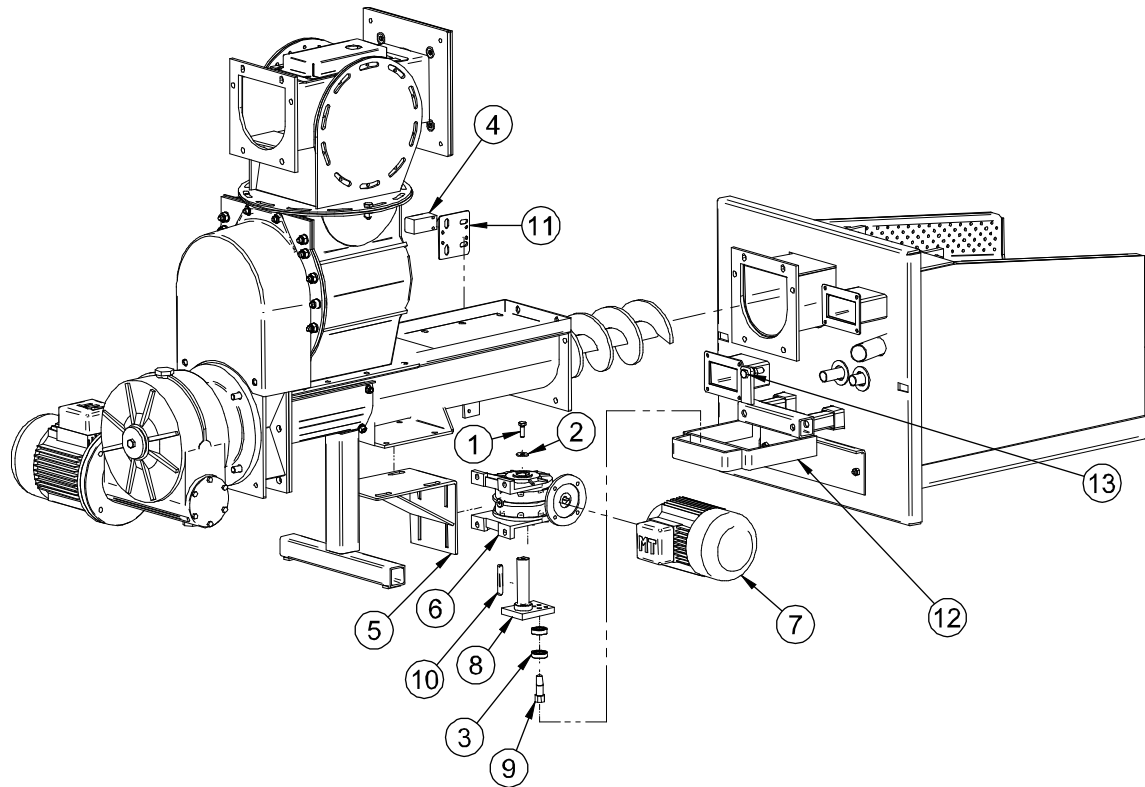

- 1 Hex screw M8x20
- 2 Washer
- 3 Bearing
- 4 Limit switch
- 5 Gearbox mounting base
- 6 Gearbox
- 7 Electric motor
- 8 Control shaft
- 9 Screw for adjustment plate
- 10 Key
- 11 Fixing plate
- 12 Grate actuator
- 13 Limit switch adjustment

1. Install the feeding screw.
2. Install the burner head and the rotary feeder with gaskets in a straight line.
Tighten the bolts.
3. Apply sealing compound on the sealing surface of the covers.
4. Install the covers.
Tighten the bolts.
5. Fit together the gearbox mounting base (5), the gearbox (6) and the control shaft (8).
6. Turn the adjuster of the control shaft (8) to point in the direction of the silo.
7. Pull the grate actuator (12) to the maximum position.
8. Install the whole gearbox assembly on the burner head.
Do not tighten the adjustment nuts.
9. Install the bearings (3) to the screw for the adjustment plate (9) and the bearing assembly on the control shaft (8).
10. Attach the limit switch (4) and the fixing plate (11) to the limit switch bracket.
11. Adjust the moving grate glide (13) to press the limit switch down.
12. Tighten the nuts in the gearbox mounting base (5) and the limit switch (4).
13. Test the functioning by rotating the gearbox motor connection.
14. When the moving grate is correctly adjusted, install the electric motor (7).

5.3.1. Installing burner heads 160-640 kW with Veto XL control unit

Figure 8 Moving grate equipment

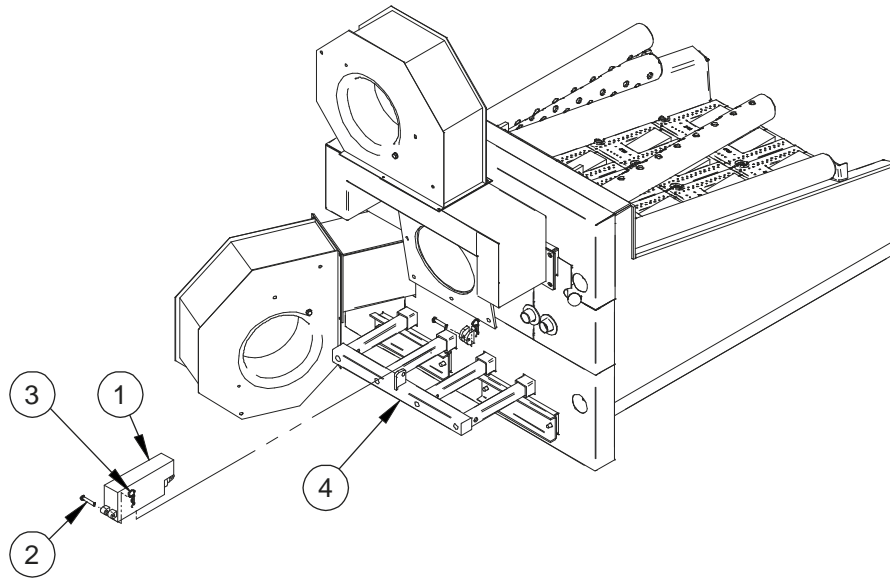

- 1 Linear actuator
- 2 Pin
- 3 Needle pin
- 4 Moving grate

1. Install the feeding screw.
2. Install the burner head and the rotary feeder with gaskets in a straight line. Tighten the bolts.
3. Apply sealing compound on the sealing surface of the covers.
4. Install the covers. Tighten the bolts.
5. Install the linear actuator (1) to the burner head.
Install the push bar towards the burner head. Fasten with a pin (2) and a needle pin (3).
6. Check that the moving grate (4) is on the right place so that you can install the other end of the motor as well. Fasten with a pin (2) and a needle pin (3).

5.3.2. Installing burner heads 800-990 kW with Veto XL control unit

Figure 9 Moving grate equipment

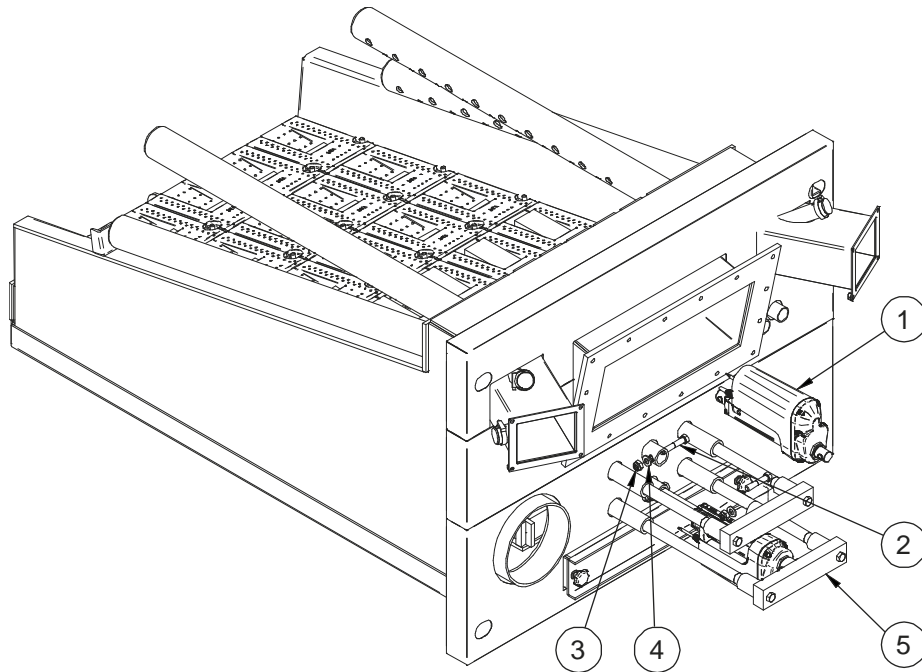

- 1 Burner head
- 2 Bolt
- 3 Nut
- 4 Washer
- 5 Moving grate

1. Install feeding screws.
2. Install the burner head and the rotary feeder with gaskets in a straight line. Tighten the bolts.
3. Apply sealing compound on the sealing surface of the covers.
4. Install the covers. Tighten the bolts.
5. Pull the moving grate (5) to the outermost position.
6. Install the linear actuators (1) to the burner head.
Install the push bar towards the burner head. Install the upper motor bottom down and the lower motor bottom up. Fasten with a bolt (2), a washer (4) and a nut (3).
7. Check that the moving grate (5) is on the right place so that you can install the other end of the motor as well. Fasten with a bolt (2), a washer (4) and a nut (3).

5.4. Before taking the system into use

- Check that the system is filled with water and vented.
- Check that the water circulates also in the burner head.
- Test that the limit switch of the grate unit is adjusted correctly.
- Check that the secondary air pipes are installed correctly.
 - Install the secondary air pipes so that the upper hole rows (A) are perpendicularly towards each other. The lower hole rows (B) remain at a 45° angle upwards.
 - Tighten the secondary air pipes with screws (1).

Figure 10 Moving grate equipment

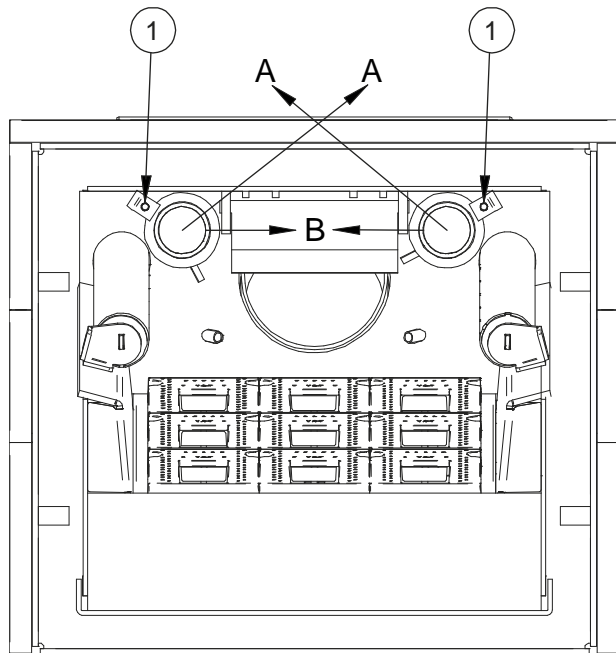

1 Screw

A Upper hole rows

B Lower hole rows

NOTICE

360, 480, 640, 800, and 990 kW burner heads include secondary air pipes.

6. Service

DANGER

Service of the device must only be performed by an authorized professional following all the requirements of the authority having jurisdiction over the action.

Risk of burn! Before servicing, turn the operating switch to the 0 position and turn off the main switch. Let the boiler cool down sufficiently.

Risk of carbon monoxide poisoning! Service the boiler only when it is cold and contains no hot ashes. In case fire is still burning or there are embers left in the boiler when service measures are started, carbon monoxide spreads from the open service doors to the boiler room.

Risk of carbon monoxide poisoning and fire! Do not collect ash in a plastic or cardboard box. Ashes containing embers develop carbon monoxide and cause fire hazard even when collected in a container made of incombustible materials.

CAUTION

Ashes or fuel may contain constituents causing allergic reactions.

- Use appropriate protective equipment, especially respirator mask, when handling ashes or fuel.
- Use clothes and gloves made of infusible materials when servicing the burner head.

6.1. Service schedule

Table 12 Service schedule

	Daily	Monthly	Half-yearly	Yearly
Check the overall condition and functioning of the devices.	x			
Remove the ash from inside the burner head.		x		
Check the gearing for visible leakages.		x		
Check that the surface of the gearing is dry.		x		
Brush the air holes in the casting parts of the burner head open.			x	
Clean the blower's impeller blades.			x	
Check the condition and paths of the moving parts.			x	
Change the beeswax plug in the muff of the backfire prevention system.				x



CAUTION

Follow also the local authorities' rules for servicing.

6.2. Preparing for service

1. Burn all the fuel inside the burner.
2. Switch the burner off.
3. Let the burner and the boiler cool down.

Tools needed for service:

- Cleaning rake
- Wire brush

6.3. Removing ash from inside the burner



WARNING

Before removing the ash, shut down the burner and allow it to cool down.

- Remove ash from inside the burner head once a month or when needed.
- Open the lid below the rear section of the burner head and remove the ash with a suitable tool.



WARNING

The accumulated ash inside the burner head weakens the operation of the cooling system. Too much ash inside the burner head could cause backfire.

Too much ash inside the burner head ash chamber can prevent the grate from moving.

Figure 11 Removing ash

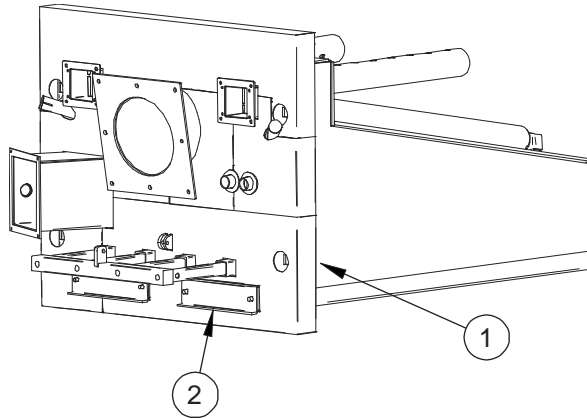

- 1 Burner head
- 2 Ash chamber lid



CAUTION

Empty the ash chamber all the way from the front section. Accumulated ash in the front section can result in breaking down the moving grate or the bearing.

Figure 12 Removing ash from the front section

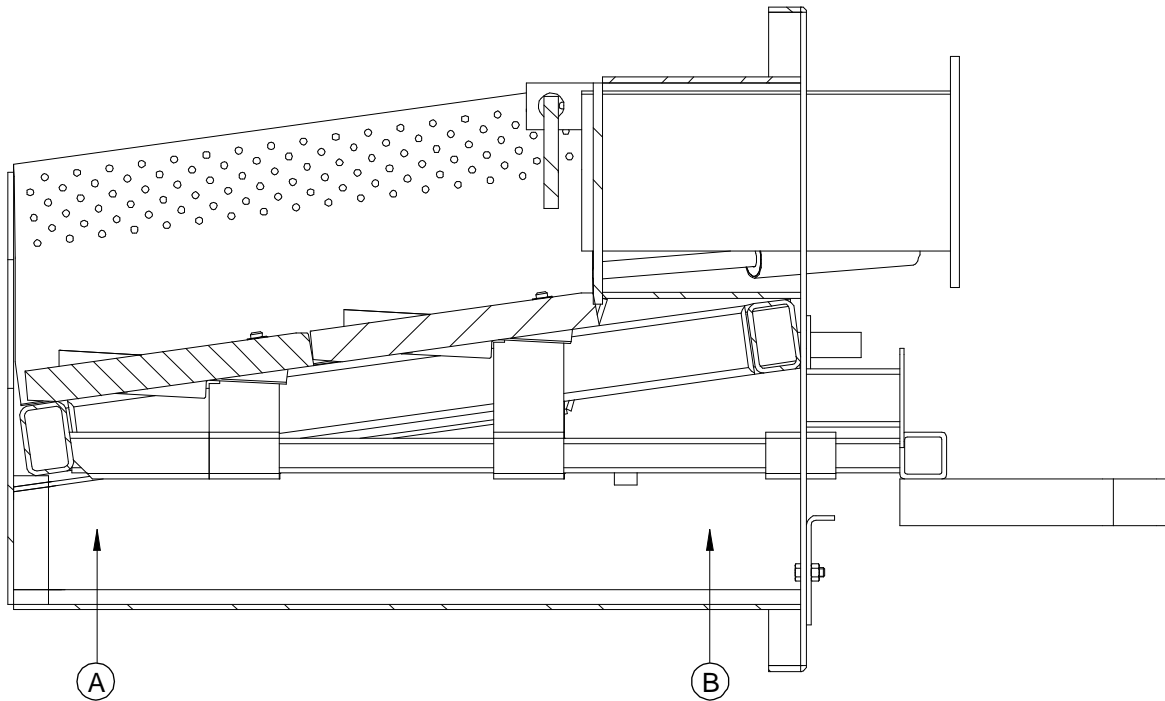

- A Front section
- B Rear section

6.4. Cleaning the burner head air holes

- Brush the air holes in the casting parts of the burner head open twice a year with a wire brush, for example.
- Remove obstacles that might come into the burner head with fuel, for example nails, from the grate.
- Check the condition of the moving parts once a year.

6.5. Changing bottom bricks

1. Move the grate tongue to its rear position.
The grate tongue should be visible as little as possible.
2. Remove the mounting nut and the washer of a bottom brick.
3. Lift the front part of the bottom brick to remove it.

NOTICE

When removing the old bricks, start from the bottom row. New bottom bricks are installed in reverse order.

4. If the mounting screw has burnt off, weld an M10x25 uncoated screw (hardness 8.8) to the same spot.

CAUTION

When welding the new screw, make sure that the welding does not burn through. The weld seam must be waterproof.

7. Troubleshooting

7.1. Burner heads with a moving grate

7.1.1. Grate actuator bearing damaged

Possible cause	Solution
Ash or sand in the air space under the moving grate (especially in the front section).	Empty the whole air space starting from the very front of the space. The front part of the grate push bars must be open. Replace grate actuator bearing.

7.1.2. Ash does not exit the burner head

Possible cause	Solution
The bearings are damaged.	Replace the bearings.

7.2. Burner heads with a moving or stationary grate

7.2.1. Ash does not exit the burner head

Possible cause	Solution
The moving grate is incorrectly adjusted.	Readjust the moving grate.
The moving grate is not moving. The grate tongues are blocked. (The motor protection has tripped.)	Remove sintered ash and other obstacles (e.g. nails) from the moving grate.

The moving grate is not moving. The motor protection has tripped.	Lubricate the grate push bar inlets with copper grease.
	Remove the buildup ash inside the burner head.
	The bottom bricks have burnt off. Replace.

7.2.2. Unburnt fuel in the ash chamber

Possible cause	Solution
There is not enough air.	Readjust the primary and the secondary air supply.
Too much fuel is fed to the system in comparison with the burner head output.	Reduce the fuel supply and readjust the air supply.
The moving grate moves but performs two operation time sequences.	The pulse time for the operating condition is set too long.
The moving grate moves but does not pause.	Readjust the limit switch.
The pause time for the moving grate is too short.	Make the pause time longer in TA control unit.

7.2.3. Bottom bricks burnt off

Possible cause	Solution
The circulation pump is not running.	Replace the circulation pump.
There is air in the piping and the cooling is not working.	Vent the network. Replace the circulation pump.
Ash does not exit the moving grate.	Replace the bottom bricks.
The grate tongues have burnt into their outermost position.	Readjust the grate unit. Replace the grate tongue.
The tips of the grate tongues have worn out.	Readjust the grate unit. Replace the grate tongue.

7.2.4. Burner smokes

Possible cause	Solution
The burner is adjusted incorrectly or the burner head is cold.	Let the burner head warm up or adjust the burner head to correspond to the current fuel.
The secondary air is incorrectly adjusted.	Check the condition of the secondary air plates. Adjust the amount of air.
The fuel is too damp and the combustion heat does not rise sufficiently.	Change to dryer fuel.
The burner does not receive enough air.	Check the condition of the burner head and the air holes.
	Readjust the primary and secondary air and check the replacement air supply.
The blower impellers are clogged.	Clean the impellers.
The moving grate holes are blocked.	Clean the holes.

7.3. Linear actuator

7.3.1. Moving grate does not move

Possible cause	Solution
Ash or sand in the air space under the moving grate (especially in the front section).	Empty the whole air space starting from the very front of the space. The front part of the grate push bars must be open. Change the linear actuator.

8. Device components and spare parts

Figure 13 Burner heads 160 and 240 kW spare parts (A•T Log-1, A•T Log-2 and Lambda 5S control units)

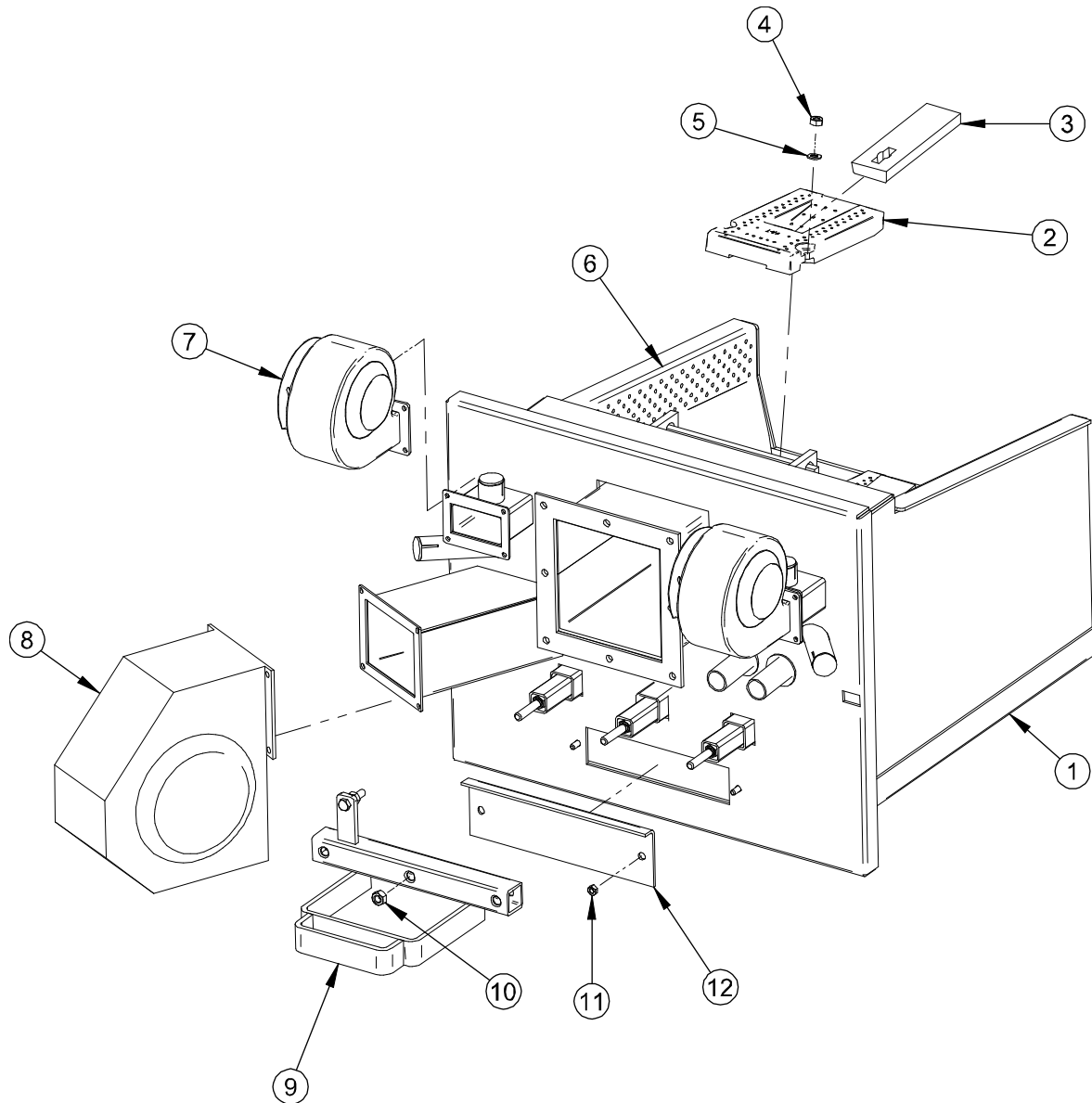

Table 13 Burner heads 160 and 240 kW spare parts (A•T Log-1, A•T Log-2 and Lambda 5S control units)

No.	Name	Item
1	Burner head 160 kW Ø125 mm	
	Burner head 160 kW Ø160 mm	
	Burner head 240 kW Ø125 mm	
	Burner head 240 kW Ø160 mm	
2	Burner head stone	32265
3	Grate tongue	42864
4	Nut M10 DIN 934	73330
5	Washer M10	73106
6	Secondary air plate	32259
7	Blower RFE 140	62144
8	Blower RFE 200 (240 kW)	621441
	Blower RFE 140 (160 kW)	62144
9	Grate push bars	42033
	Grate push bars 240	42037
10	Nut M12	73332
11	Nut M8	73308
12	Ash box lid	42317

Figure 14 Burner heads 360-640 kW spare parts (A•T Log-1, A•T Log-2 and Lambda 5S control units)

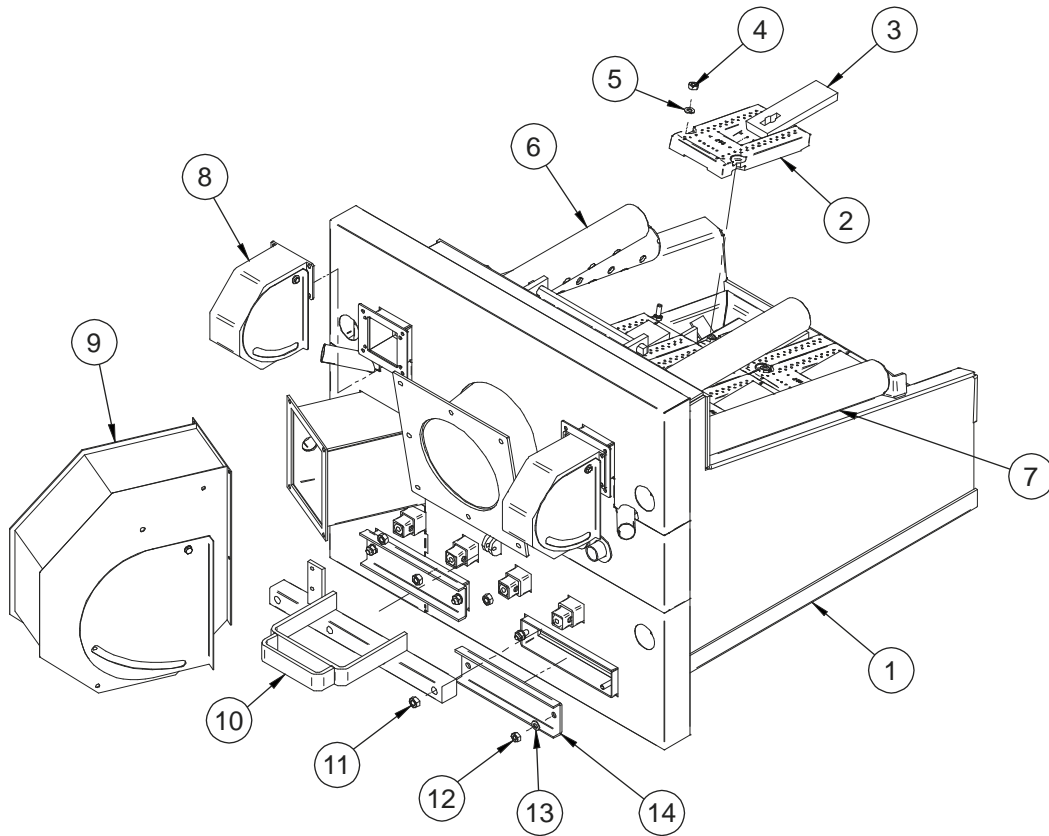

Table 14 Burner heads 360-640 kW spare parts (A•T Log-1, A•T Log-2 and Lambda 5S control units)

No.	Name	Item
1	Burner head 360 kW	
	Burner head 480 kW	
	Burner head 640 kW	
2	Burner head stone	32265
3	Grate tongue	42864
4	Nut M10 DIN 934	73330
5	Washer M10	73106
6	Secondary air pipe 1 (360/480 kW)	48712
	Secondary air pipe 1 (640 kW)	34454
7	Secondary air pipe 2 left (360/480 kW)	48708
	Secondary air pipe 2 right (360/480 kW)	48707
	Secondary air pipe 2 left (640 kW)	34455
	Secondary air pipe 2 right (640 kW)	34455_mir
8	Blower RFE 140 (360-640 kW)	11109
9	Blower RFE 200 (360 kW)	11109-1
	Blower RFE 250 (480/640 kW)	11109-2
10	Grate push bars 360	42034
	Grate push bars 480/640 kW	46941
11	Nut M12	73332
12	Nut M8	73308
13	Washer M8	73104
14	Ash box lid	42317

Figure 15 Burner heads 160-640 kW spare parts (Veto XL control unit)

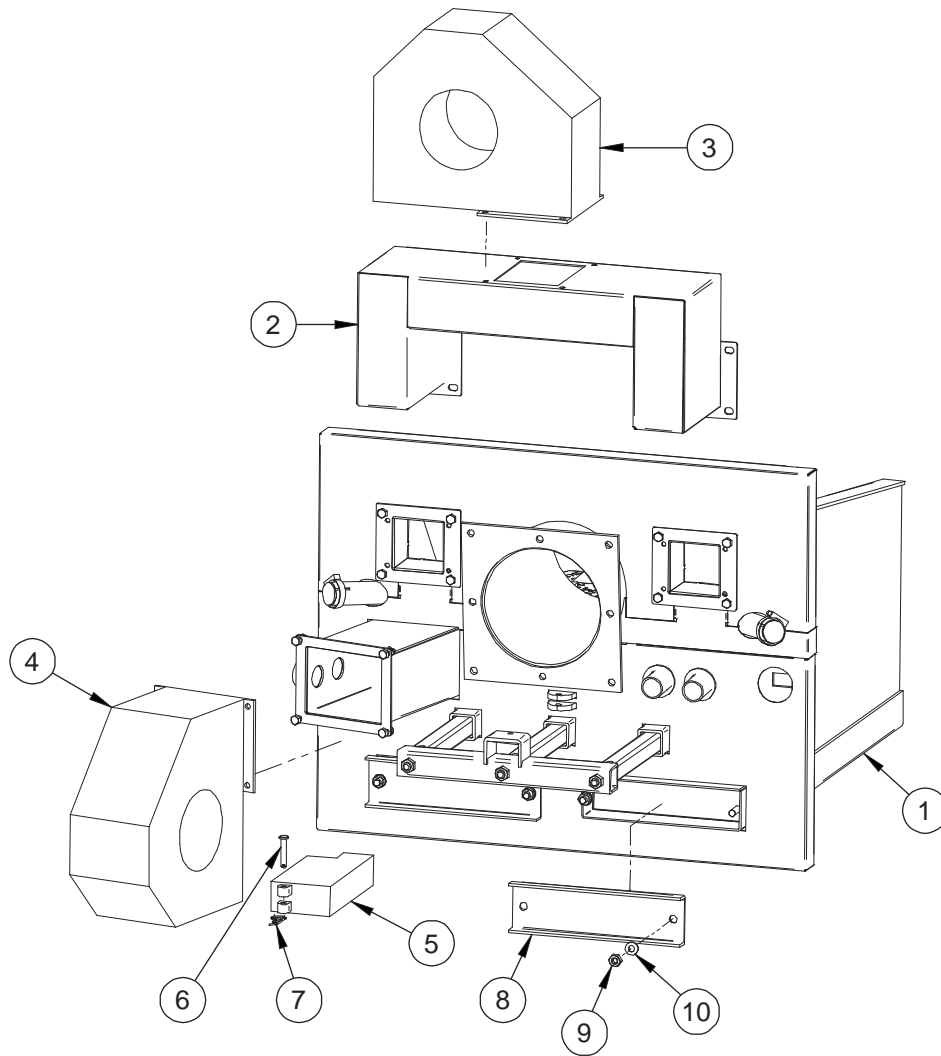

Table 15 Burner heads 160-640 kW spare parts (Veto XL control units)

No.	Name	Item
1	Burner head 160 kW	
	Burner head 240 kW	
	Burner head 360 kW	
	Burner head 480 kW	
	Burner head 640 kW	
2	Secondary air box 160 kW	
	Secondary air box 240, 360 kW	48721
	Secondary air box 480, 640 kW	46941
3	Blower RFT 140 (160 kW)	11109
	Blower RFT 200 (240 kW)	11109-4
	Blower RFT 200 (360 kW)	11109-5
	Blower RFT 250 (480/640 kW)	11109-6
4	Blower RFT 140 (160 kW)	11109
	Blower RFT 200 (240 kW)	11109-4
	Blower RFT 200 (360 kW)	11109-5
	Blower RFT 250 (480/640 kW)	11109-6
5	Linear actuator	620313
6	Pin DIN 1444B	
7	Needle pin	74149
8	Ash box lid	42317
9	Nut M8	73308
10	Washer M8	73104

Figure 16 Burner heads 800-990 kW spare parts

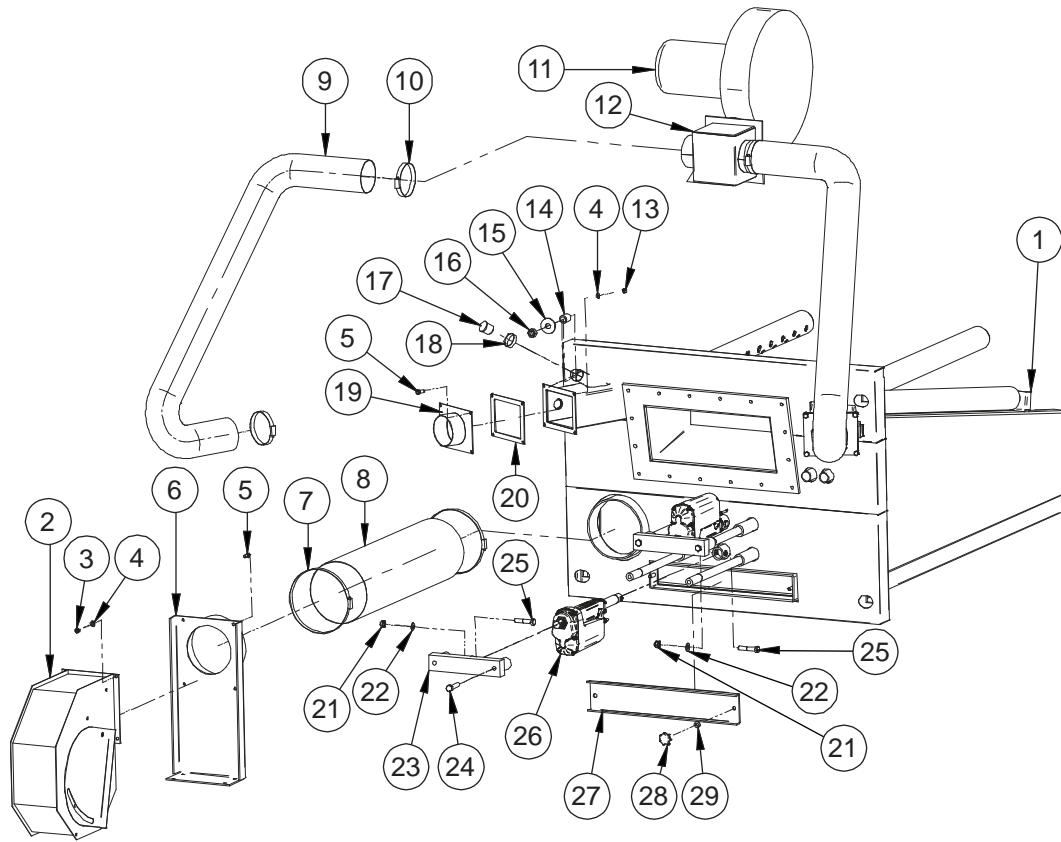

Figure 17 Burner heads 800-990 kW spare parts

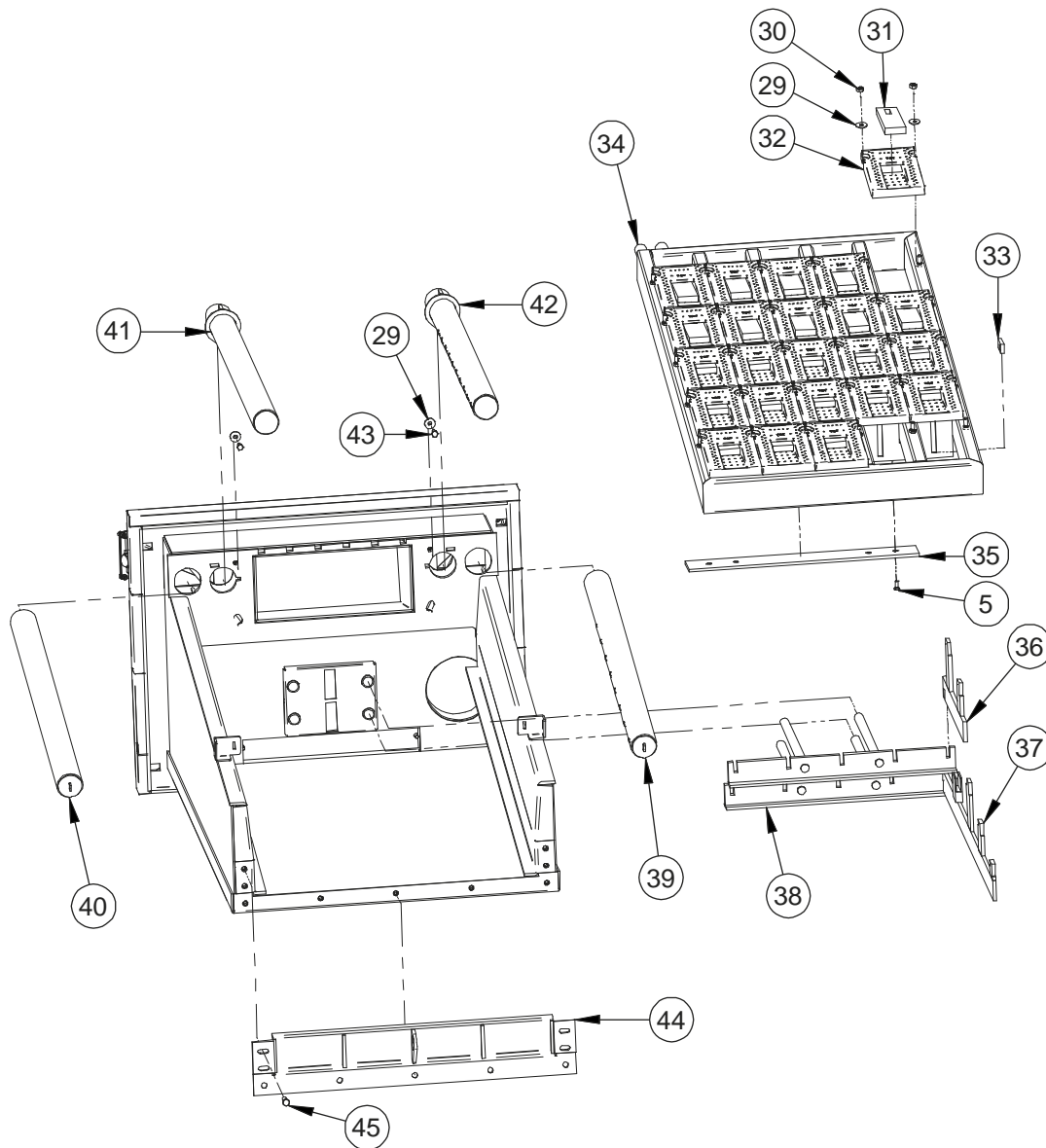

Table 16 Burner heads 800-990 kW spare parts

No.	Name	Item
1	Burner head	4-8615
2	RFT 250 assembled	1-1109-5
3	M8 nyloc	72320
4	Washer M8	73104
5	Hex screw M8x20	72130
6	RFE/RFT 250 foot welding, large pipe	4-7160-1
7	Clamp screw, Ø200 feeding chute	75086
8	Ø200 hose	
9	Ø100 hose	
10	Clamp screw, Ø100 feeding chute	750828

No.	Name	Item
11	CMA-531-2T-2 blower	62149
12	CMA blower's distribution box, welded	4-9191
13	Nut M8	73308
14	Burner connection	4-4762
15	Washer M16 DIN9021	73140
16	Nut M16	73316
17	Cover plug of the electric lighter connection	4-5220
18	Clamp screw, Ø35 feeding chute	75082
19	Adapter for the CMA blower	4-9199
20	Blower gasket RFE/RFT 200	4-5222
21	M12 nyloc	72324
22	Washer M12	73108
23	Grate push bar, welded	4-7750
24	Hex screw M12x55	721731
25	Hex screw M12x60 DIN 931	7217312
26	Linear actuator LA-36	620315
27	Ash removal hatch	4-7755
28	Knob M10/50	68532
29	Washer M10	73106
30	Hex screw M10	73310
31	Grate tongue	4-9230
32	Bottom brick	3-2265
33	Guide plate, Hardox	4-5922
34	Water piping	4-4716-1
35	Support plate for the grate pipings, Hardox	4-4731
36	Grate push bar, small	4-4767-1
37	Grate push bar, large	4-4765-1
38	Grate actuator, welded	4-7752
39	Secondary air pipe, lower left	4-7777
40	Secondary air pipe, lower right	4-7775
41	Secondary air pipe, upper right	4-7773
42	Secondary air pipe, upper left	4-7772
43	Hex screw M10x25	72150
44	Front plate, welded	4-4777-1
45	Hex screw M12x35	721512

9. Disposal of the burner head

When used and serviced properly, the burner head will serve you for a long time. In time it will, however, become unprofitable to maintain and thereby be disposed of.

Deliver the device to a waste treatment plant where it is taken to pieces and the parts are recycled in an appropriate way.

